



**TOWN OF BLACKFALDS
BLACKFALDS CEMETERY
Box 220, Blackfalds, AB T0M 0J0
Phone 403-885-4677 Fax 403-885-4610**

Application for: Monument Permit for Plot _____ Lot _____ Block _____

Name of Plot Owner/Purchaser: _____

Address: _____ Phone No.: _____

I, _____, company representative apply for a permit for the installation of a Monument/Marker as shown on the details of this application for the above plot in accordance with the requirements of Bylaw _____ on behalf of _____ Owner/Executor for the deceased _____ (Name).

The Owner/Executor has authorized the installation as indicated by his/her signature given on this application.

Signature Owner/Executor	Company Name	Address
	Signature Company Representative	Phone Number

Valid Town of Blackfalds Business License: Yes/No If "No" enclose license fee.

Concrete Foundations Required for Mounting both Upright Monuments and Flat Markers:

Upright Monument Description:

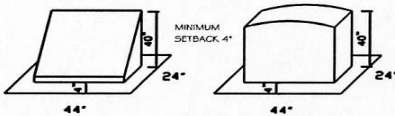

Monument Material _____
Upright Monuments are only allowed in Blocks 1, 3, 6, 7, 11, A, B, C & D.

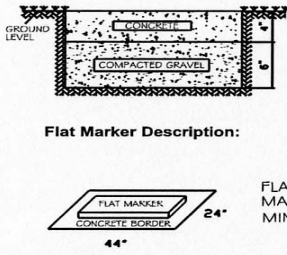

Flat Marker Description:

FLAT MARKER
MAXIMUM HEIGHT 1"
MINIMUM SETBACK 4"

Marker Material _____

r rules and regulations regarding monument and marker installations.

Certification of Installation: I, _____ hereby certify that the above monument or marker has been installed in accordance with all provisions of Bylaw _____.

Signature of Installer: _____ Date: _____

Address: _____ Phone: _____

This permit shall be returned to the Town of Blackfalds office following certification of installation.

For Office Use Only

Installation checked and approved: _____ Date: _____
CSD Representative or PW

ALL MONUMENTS MUST BE PLACED IN ACCORDANCE WITH THE TOWN OF BLACKFALDS CEMETERY BYLAW AND ARE VALID FOR 60 CALENDAR DAYS FROM THE DATE OF APPLICATION.