

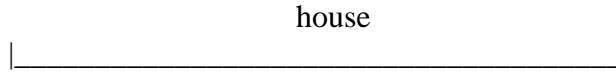

Please show deck below complete with post and beam locations and dimensions:

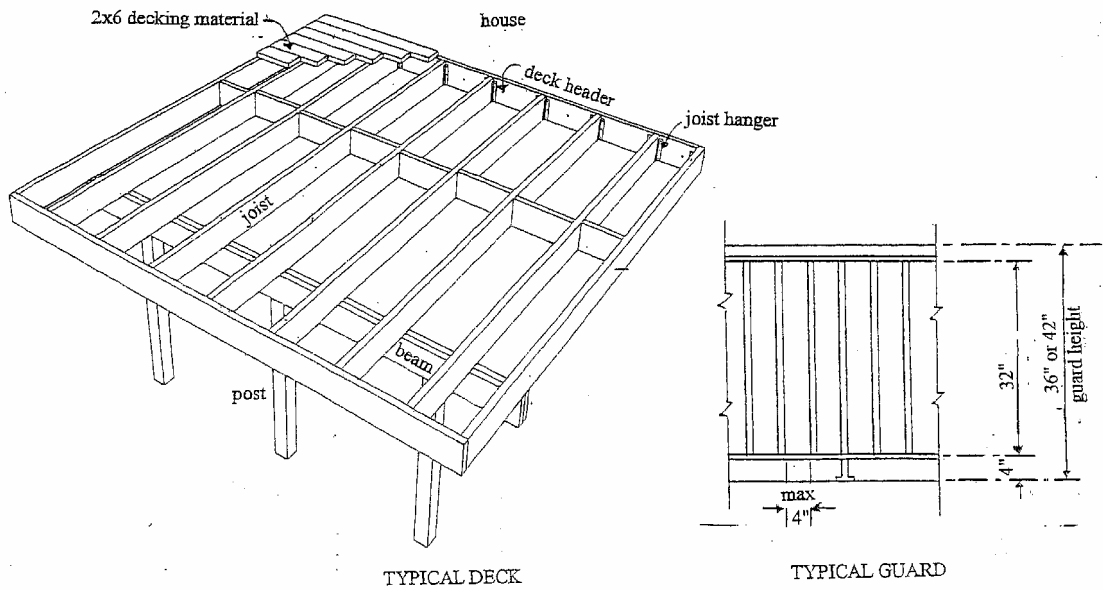

Diagrams below for information only:



A final inspection will be required. Additional items may be identified at this time.

For more information, contact the Planning & Development Officer 885-4677.